

## Rechargeable Sealed Lead-Acid Battery

# PS-1220

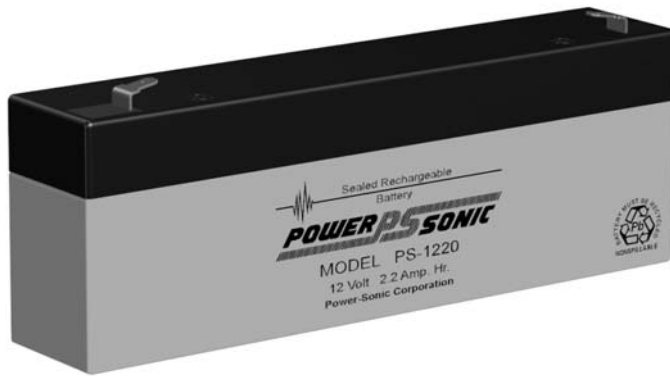

**Power-Sonic** rechargeable batteries are lead-lead dioxide systems. The dilute sulphuric acid electrolyte is suspended and thus immobilized. Should the battery be accidentally overcharged producing hydrogen and oxygen, special one-way valves allow the gases to escape thus avoiding excessive pressure build-up. Otherwise, the battery is completely sealed and is, therefore, maintenance-free and leak proof.

PS-1220 is air transport approved, and meets all current requirements set forth by the C.A.B., F.A.A., I.A.T.A. and D.O.T.

U.L. recognizes model PS-1220 under file number MH 14328.

### PERFORMANCE SPECIFICATIONS

<b>Nominal Voltage</b> .....	12 volts (6 cells in series)
<b>Nominal Capacity</b>	
20 hour rate (110mA to 10.50 volts) .....	2.2 A.H.
10 hour rate (210mA to 10.50 volts) .....	2.1 A.H.
5 hour rate (370mA to 10.20 volts) .....	1.85 A.H.
1 hour rate (1400mA to 9.00 volts) .....	1.4 A.H.
<b>Approximate Weight</b> .....	2.05 pounds (0.93 kg)
<b>Energy Density (20 hour rate)</b> .....	1.19 Watt-hours/cubic inch (72.7 Watt-hours/l)
<b>Specific Energy (20 hour rate)</b> .....	12.9 Watt-hours/pound (28.4 Watt-hours/kg)
<b>Internal Resistance (Fully Charged Battery)</b> .....	55 milliohms (approximately)
<b>Maximum Discharge Current ( ≤ 7 Min.)</b> .....	7 amperes
<b>Maximum Short-Duration Discharge Current ( ≤ 10 Sec.)</b> .....	22 amperes
<b>Terminals</b> .....	Quick disconnect tabs, 0.187" x 0.032" Mate with AMP. INC FASTON "187" series
<b>Vibration Test (2000 cycles/minute, 0.10 inch excursion, 2 hours)</b> .....	No loss in capacity or performance
<b>Shelf Life — % of nominal capacity at 68° F (20° C)</b>	
1 Month.....	97%
3 Months.....	91%
6 Months.....	83%
<b>Operating Temperature Range</b>	
<b>Charge</b> .....	-4°F (-20°C) to 122°F (50°C)
<b>Discharge</b> .....	-4°F (-20°C) to 140°F (60°C)
<b>Case</b> .....	ABS Plastic (Acrylonitrile Butadiene Styrene Copolymer)

**Shelf Life and Storage**

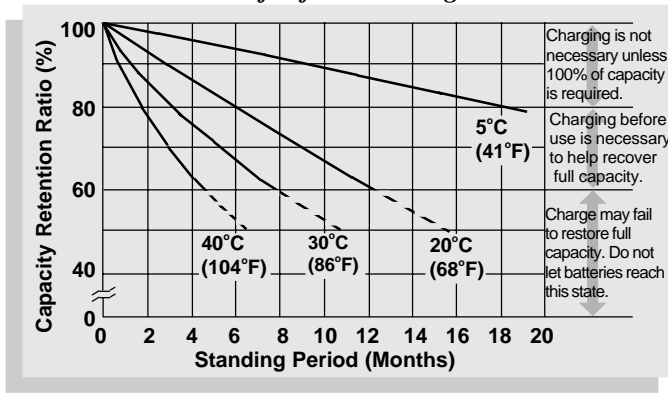

**Discharge Characteristics**

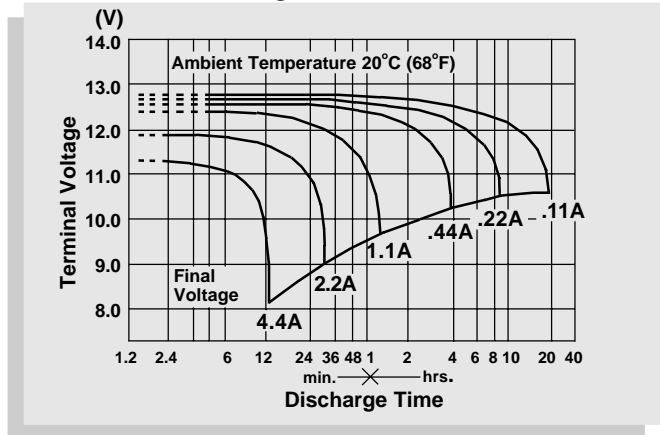

**Life Characteristics in Stand-By Use**

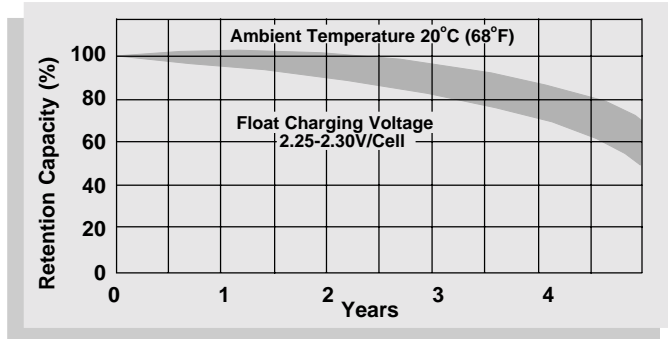

**Discharge Time vs. Discharge Current**

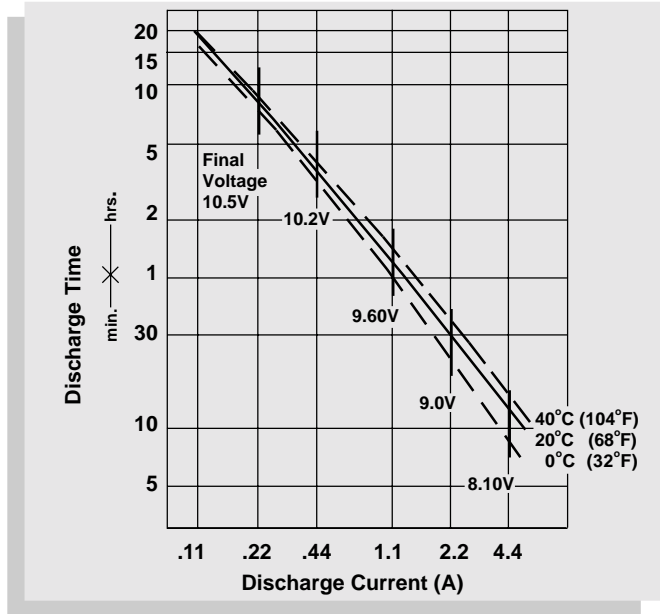

**Life Characteristics in Cyclic Use**

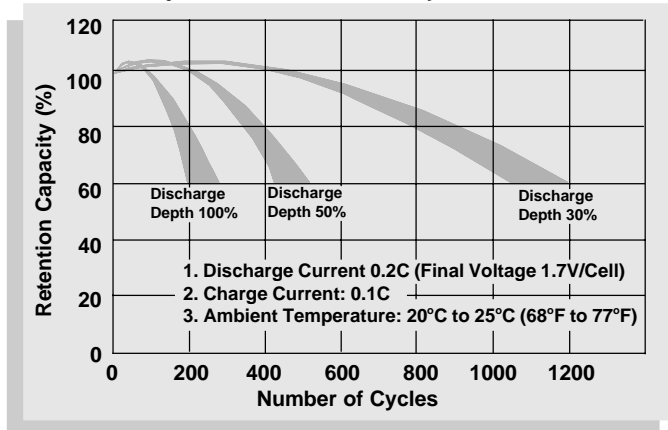

Physical Dimensions: in. (mm)

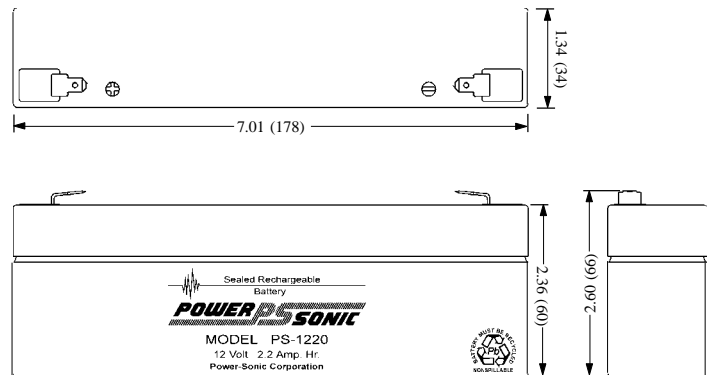

Tolerances are +/- 0.04 in. (+/- 1mm) and +/- 0.08 in. (+/- 2mm) for height dimensions.

**CHARGING**

**Cycle Applications:** Limit initial current to 440mA. Charge until battery voltage (under charge) reaches 14.40 to 14.70 volts at 68°F (20°C). Hold at 14.40 to 14.70 volts until current drops to approximately 22mA. Battery is fully charged under these conditions, and charger should either be disconnected or switched to "float" voltage.

**"Float" or "Stand-By" Service:** Hold battery across constant voltage source of 13.50 to 13.80 volts continuously. When held at this voltage, the battery will seek its own current level and maintain itself in a fully charged condition.

**NOTE:** Due to the self-discharge characteristics of this type of battery, it is imperative that they be charged after 6-9 months of storage, otherwise permanent loss of capacity might occur as a result of sulfation.



**SALES & MARKETING**  
 3106 Spring Street  
 Redwood City, CA 94063 USA  
 Tel: 415-364-5001 Fax: 415-366-3662  
 rwcsales@power-sonic.com

www.power-sonic.com

**CUSTOMER SERVICE**  
 9163 Siempre Viva Road  
 San Diego, CA 92173 USA  
 Tel: 619-661-2030 Fax: 619-661-8033  
 battery@power-sonic.com